

## FB33-12

12V33Ah Lead Acid Battery

Unit: inch(mm)

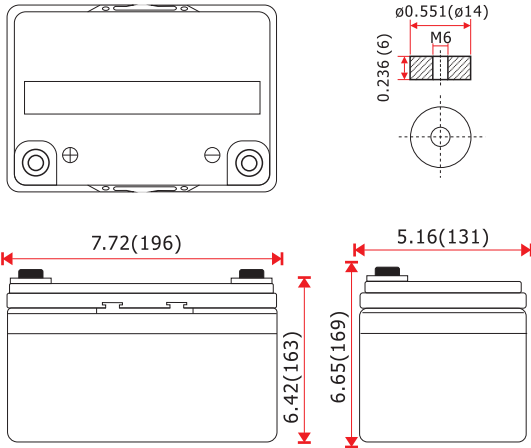

### Discharge Current and Discharge Duration Time

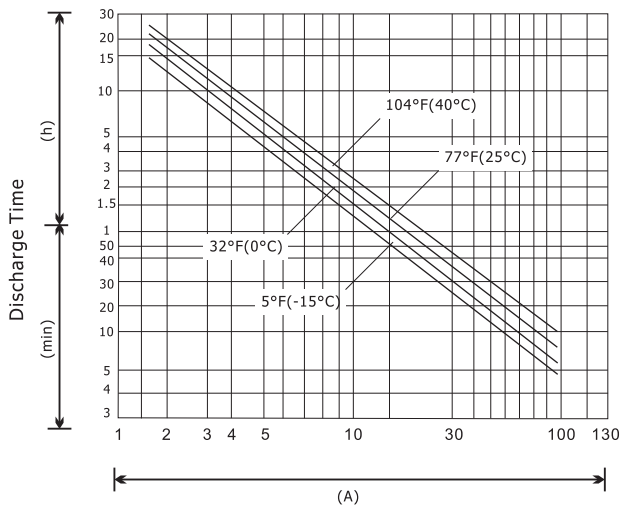

Discharge Curves 77°F(25°C)

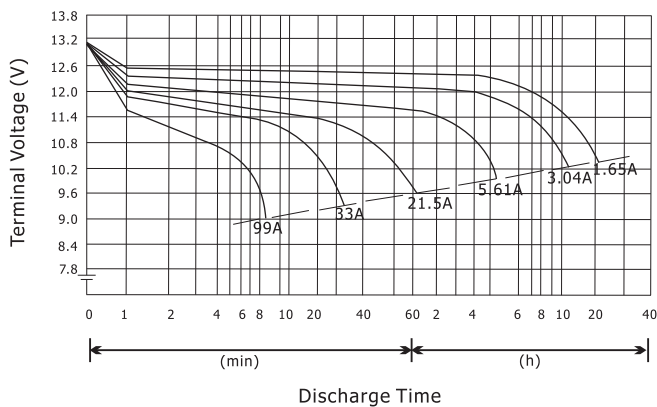

### Specification

Nominal Voltage	12V	
Rated Capacity (20hr Rate)	33Ah	
Dimensions	Length	7.72inches (196mm)
	Width	5.16inches (131mm)
	Height	6.42inches (163mm)
	Total Height	6.65inches (169mm)
Weight	Approx. 21.56lbs (9.78kg)	
<b>Characteristics</b>		
Capacity 77°F(25°C)	20hour rate (1.65A)	33.0Ah
	10hour rate (3.04A)	30.4Ah
	5hour rate (5.61A)	28.1Ah
	1hour rate (21.5A)	21.5Ah
Internal Resistance	Full Charged, 77°F(25°C)	10mΩ
Capacity Affected By Temperature (10hr Rate)	104°F(40°C)	102%
	77°F(25°C)	100%
	32°F(0°C)	85%
	5°F(-15°C)	65%
Self-Discharge 77°F(25°C)	Capacity after 3 month storage	90%
	Capacity after 6 month storage	80%
	Capacity after 9 month storage	60%
Charge (Constant Voltage)	Initial Charge Current "LESS" than 9.9A	
	Cycle	14.4-15.0V/77°F(25°C)
	Stand By	13.5-13.8V/77°F(25°C)

\*\*These data are average values obtained from three Charge/Discharge cycles. Note: These are NOT minimum values.

## Constant Current Discharge Characteristics Unit: A (25°C / 77°F)

F.V/Time	5MIN	10MIN	15MIN	30MIN	1HR	2HR	3HR	5HR	8HR	10HR	20HR
9.6V	123	84.5	63.4	38.6	22.8	13.0	9.50	6.07	4.03	3.30	1.82
10.0V	114	79.5	60.4	37.3	22.4	12.8	9.37	5.97	3.96	3.23	1.79
10.2V	109	77.2	58.7	36.6	22.2	12.6	9.27	5.94	3.93	3.20	1.75
10.5V	100	72.6	56.1	35.3	21.7	12.4	9.11	5.87	3.86	3.17	1.72
10.8V	90.4	67.3	52.8	34.0	21.3	12.1	8.91	5.71	3.76	3.10	1.65
11.1V	79.2	60.4	48.5	32.7	20.9	11.9	8.58	5.61	3.70	3.07	1.58

## Constant Power Discharge Characteristics Unit: W (25°C / 77°F)

F.V/Time	5MIN	10MIN	15MIN	30MIN	1HR	2HR	3HR	5HR	8HR	10HR	20HR
9.6V	1321	935	732	448	261	148	108	70.6	46.0	37.1	20.0
10.0V	1216	875	689	435	256	146	106	69.3	45.5	37.0	19.8
10.2V	1158	848	669	428	253	144	104	68.3	45.2	36.6	19.6
10.5V	1066	795	633	415	248	141	102	67.0	44.2	36.0	19.5
10.8V	962	731	594	398	242	138	100	65.0	42.9	35.0	19.2
11.1V	855	664	556	380	235	135	97	63.4	41.9	34.0	18.2

### Trickle / Float Service Life

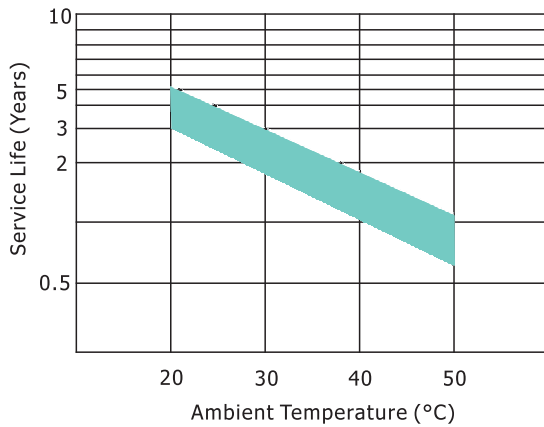

### Effect of Temperature on Capacity

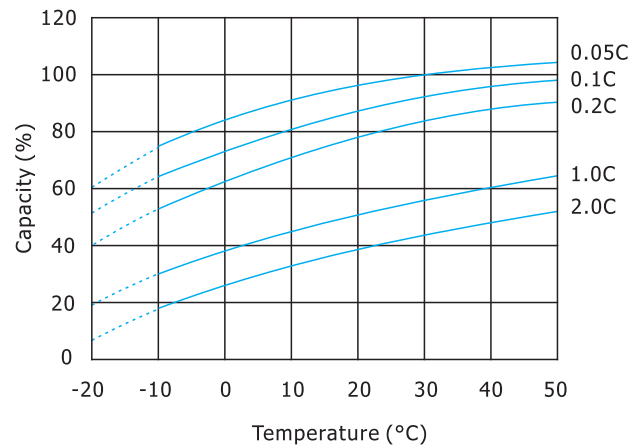

### Cycle Service Life (@25°C/77°F)

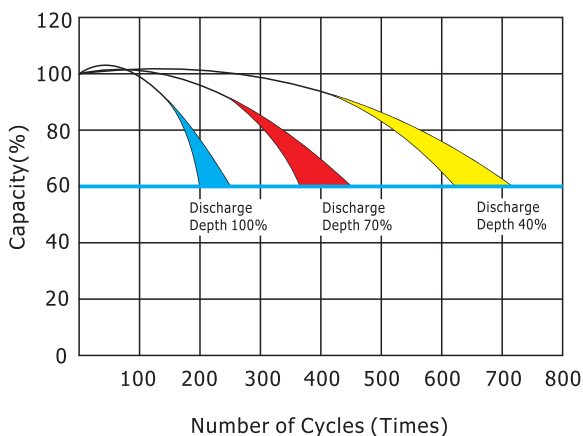

### Capacity Retention Characteristic

